

**E88
E88C
E88CS
E88O**

**HAND DRYER
220-240V 50/60HZ**

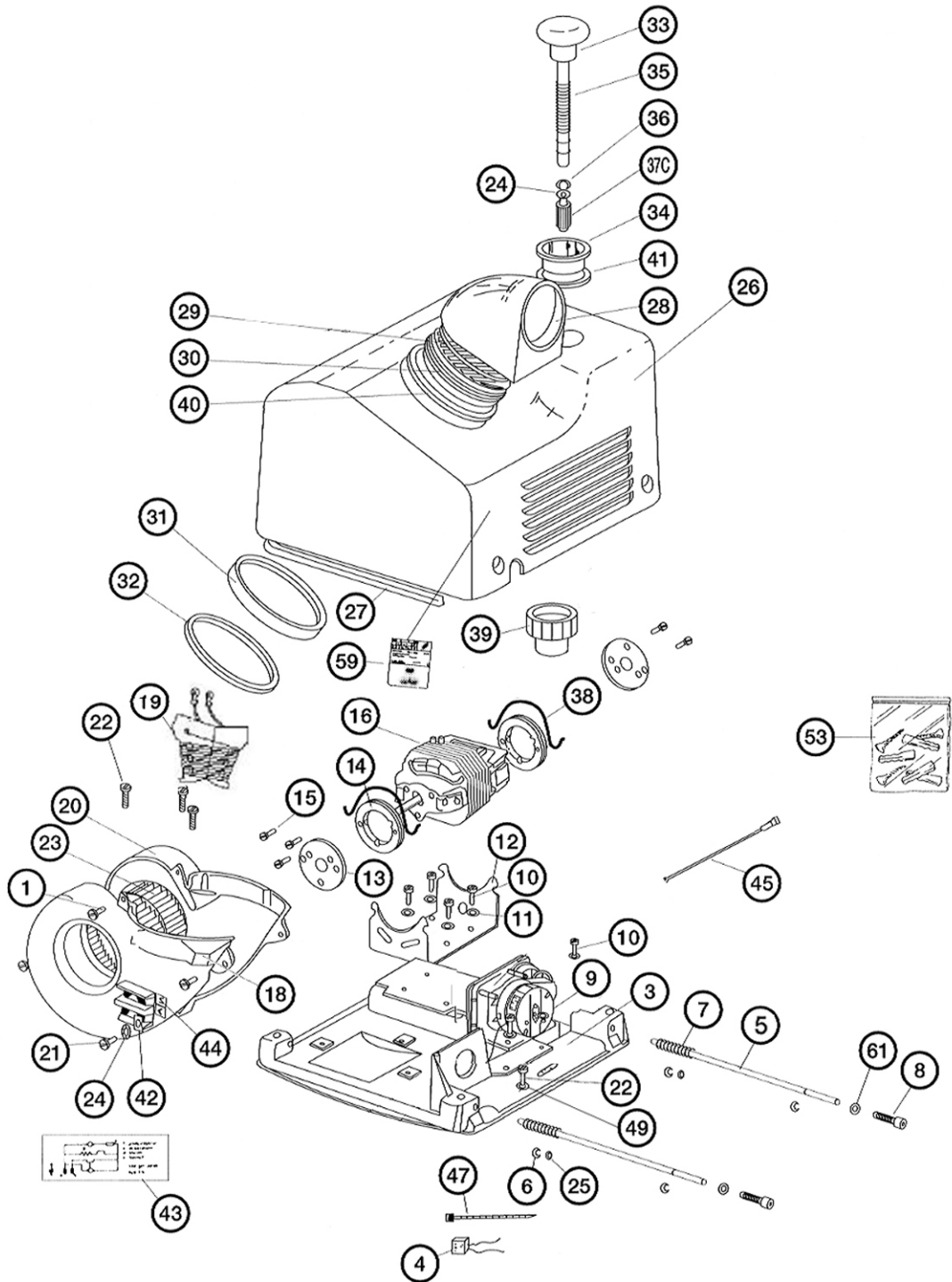

N°	NAME	MATERIAL	QTY
1	SCROLL SCREW		3
3	BASE PLATE	ALUMINIUM	1
4	R.I. FILTERS		1
5	FIXATION ROD BASE-COVER	FORAL (F - 212)	2
6	CIRCLIP	STEEL	4
7	ROD SPRING	STEEL	2
8	SAFETY SCREW	CALIBRATED STEEL	2
9	TIMER		1
10	M5*10 SCREW		7
11	INTERNAL TOOTH WASHER		6
12	MOTOR SUPPORT		1
13	SILENTBLOCK SUPPORT	P.A. 6	2
14D	SILENTBLOCK	EPDM	2
15	SCREW		5
16	MOTOR		1
18	RIGHT SCROLL		1
19	HEATING ELEMENT		1
20	LEFT SCROLL		1
21	SCREW		4
22	SCREW		4
23	FAN WHEEL	ALUMINIUM	1
24	TOOTH WASHER		3
25	ROD WASHER		2
26	COVER	STEEL	1
27	SEAL JOINT		1
28	NOZZLE	ZAMAK 5	1
29	NAZZLE SPRING	STAINLESS STEEL AISI 302	1
30	NOZZLE GRILL	ZAMAK 5	1
31	GRILL RING	ZAMAK 5	1
32	"U" JOINT	TEMOFLEX 2EVA2	1
33	PUSH-BUTTON	ZAMAK 5	1
34	PUSHBUTTON-BASE	ZAMAK 5	1
35	PUSH-BUTTON SPRING	STEEL	1
36	PUSH-BUTTON CIRCLIP	STEEL	1
37	CONTACT END		1
38	MOTOR SPRING	STAINLESS STEEL AISI 302	2
39	PUSH-BUTTON GASKET	P.A. 6	1
40	NOZZLE SILICON JOINT	SILICONE	1
41	PUSH-BUTTON SILICONE JOINT	SILICONE	1
42	PRESSURE WASHER	CK-67	2
43	ELECTRICAL SCHEME		1
44	N-L STICKER		1
45	MOTOR CABLE		1
47	CLAMP		1
49	WASHER		1
53	SCREWS/PLUGS BAG		1
59	ELEC. FEATURES LABEL		1
61	SAFETY SCREWS WASHER		2